

AVK Supa Maxi™ - gas

631/632/633/634/635

Montage instructie

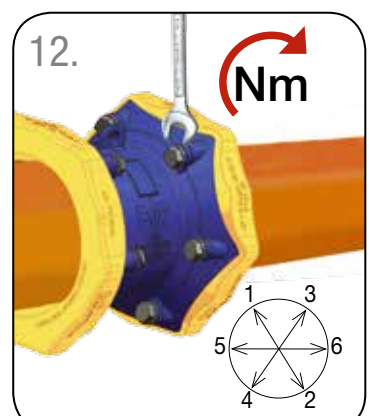
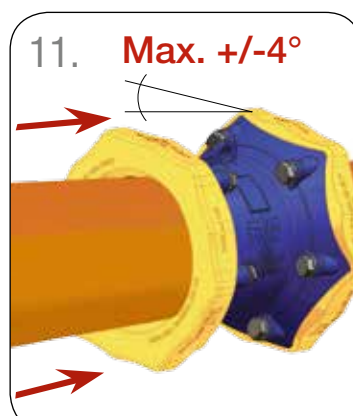
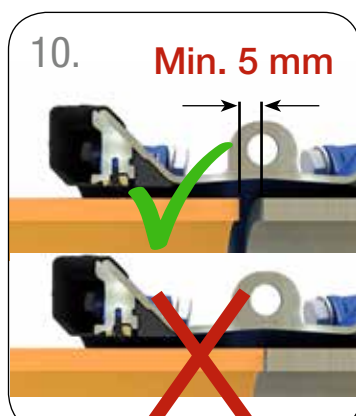
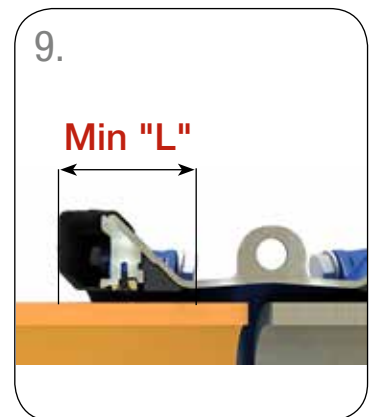
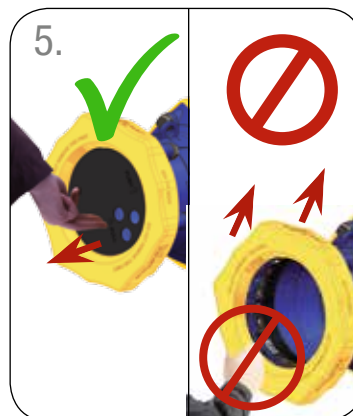
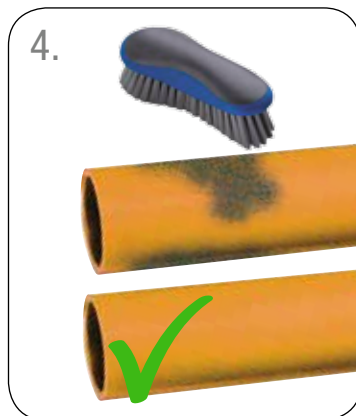
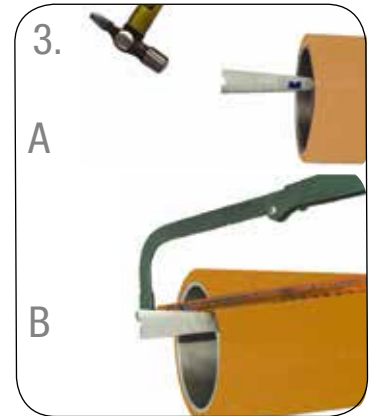
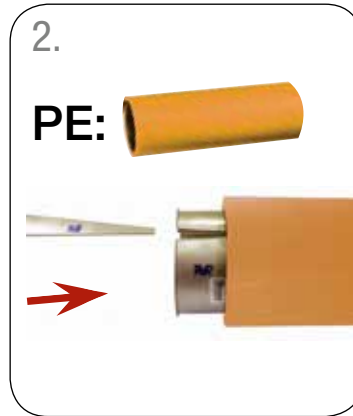

Montage instructie

AVK Supa Maxi™ 631/632/633/634/635



CONTROLEER



www.avknederland.nl

Belangrijk: Als de koppeling is gemonteerd op stalen / gietijzeren / AC leidingen en u wilt deze hergebruiken op PE/PVC leidingen, dan moeten de bronzen tandjes (elke tweede) eerst worden vervangen. Zie de afzonderlijke montage handleiding voor het vervangen van trekvast tandjes.

Bij stalen leidingen PE bekleed, moet eerst de PE verwijderd worden.

Bij toepassing op Bi-PVC buizen wordt het toepassen van een ondersteuningsbus geadviseerd.

Aandraaimoment (Nm) en min. Insteekdiepte ("L")

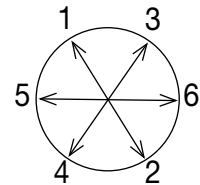

DN	Tolerantie mm	Bouten # x Ø x L	Nm Iron/steel Staal / ijzer / Eisen/Stahl PN 10	Nm PE/PVC PN 10	"L" min. mm
50	48-71	3 x M14 x 75 mm	60	60	89
65	69-91	3 x M16 x 75 mm	60	60	89
80	82-106	3 x M16 x 75 mm	80	80	88
100	104-133	4 x M16 x 75 mm	80	80	96
125	132-161	4 x M16 x 75 mm	100	100	88
150	159-188	4 x M16 x 90 mm	100	100	102
200	193-227	6 x M20 x 100 mm	120	120	116
225	224-257	6 x M20 x 100 mm	120	120	117
250	266-301	6 x M20 x 100 mm	140	140	117
300	314-356	8 x M20 x 100 mm	140	140	120

AVK geeft geen garantie bij gebruik op PE-buizen, zonder het gebruik van ondersteuningsbussen.